

Oil Pan Installation

Fig. 556: Applying RTV Around Perimeter Of Oil Pan & Oil Suction Port Opening
Courtesy of GENERAL MOTORS CORP.

1. Make sure that the oil pan and mounting surface on the lower crankcase are free of all oil and debris.
2. Apply a 3.5 mm bead of GM P/N 12378521 (Canadian P/N 88901148) or equivalent around the perimeter of the oil pan and the oil suction port opening.

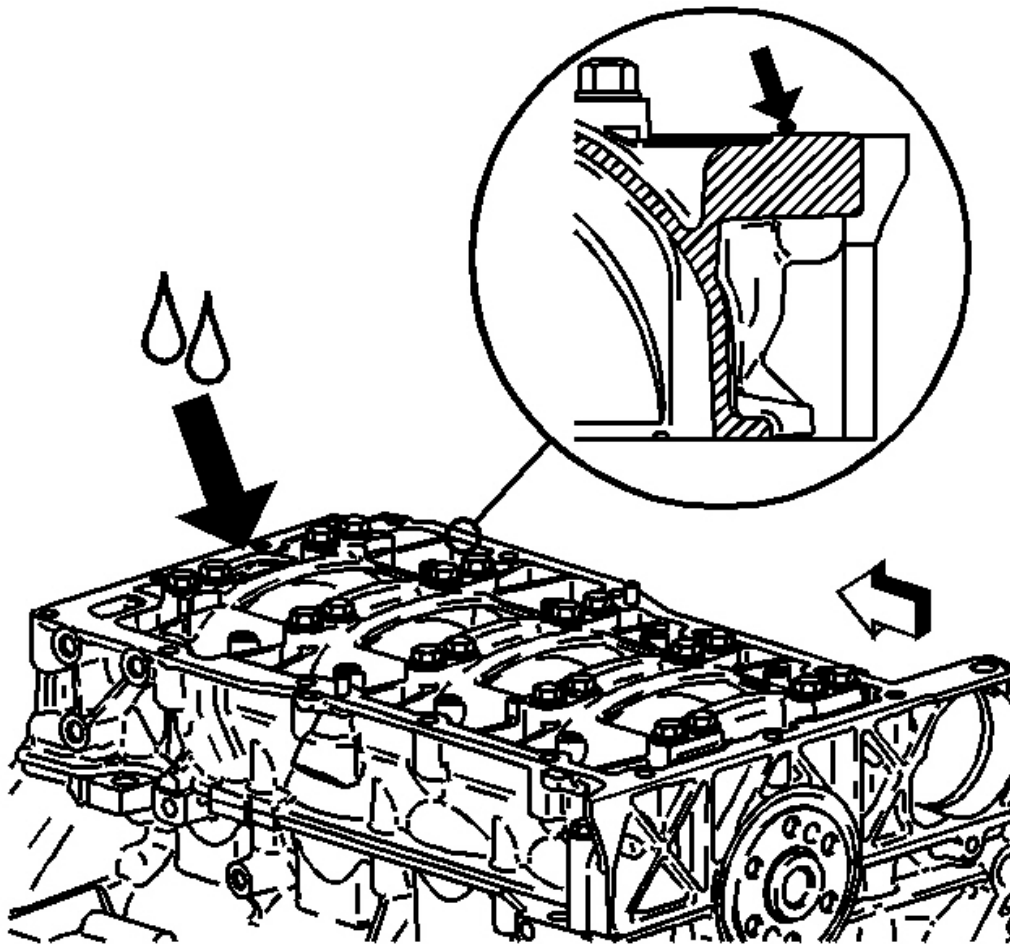
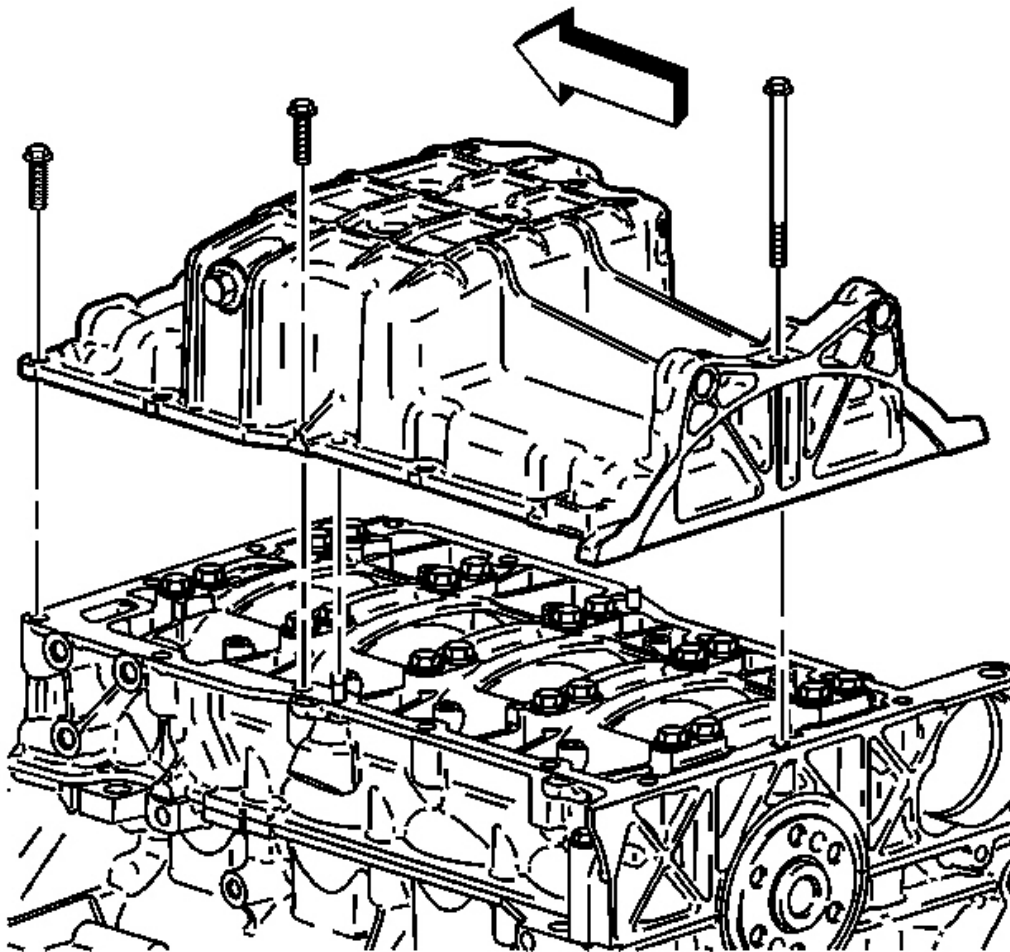

Fig. 557: View Of Oil Pan
Courtesy of GENERAL MOTORS CORP.

3. Install the oil pan.

